

Appendices and terminology

Appendices	148
■ Bearing standards	148
■ Gear teeth forces	149
Terminology	151
■ Vocabulary	151

Appendices

Bearing standards

Characteristics		Standards
► Terminology		ISO 5593
► Dimensions	Ball and roller bearings (except tapered roller and thrust bearings)	ISO 15
	Tapered roller bearings	ISO 355
	Self-aligning unit bearings	ISO 2264
	Thrust bearings	ISO 104
	Snap ring grooves	ISO 464
	Snap rings	ISO 464
	Eccentric locking collars	ISO 3145
	Tapered sleeves	ISO 113/1
	Nuts and lock-washers	ISO 2982
	Split pillow blocks	ISO 113/2
	Self-aligning bearing units	ISO 3228
Corner radii	ISO 582	
► Precision	Definitions	ISO 1132
	All types of bearings	ISO 492
	Thrust bearings	ISO 199
► Clearances	Radial internal clearance	ISO 5753
► Basic dynamic load and bearing life		ISO 281/1
► Basic static load (or basic static capacity)		ISO 76
► Thermal reference speed		ISO 15312

Gear tooth forces

T	Tangential force
C	Transmitted torque
D _p	Tooth pitch diameter

$$T = 2C / D_p$$

S	Separation forces
A	Axial forces

■ Straight-tooth cylindrical gear

α = pressure angle

$$S = T \operatorname{tg} \alpha$$

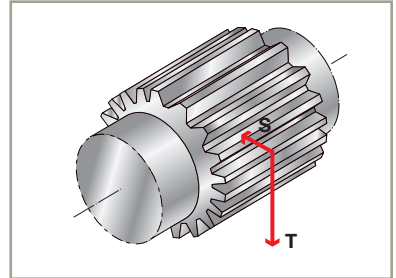

■ Helical-tooth cylindrical gear

α = pressure angle

$$S = T \operatorname{tg} \alpha / \cos \gamma$$

γ = helix angle

$$A = T \operatorname{tg} \gamma$$

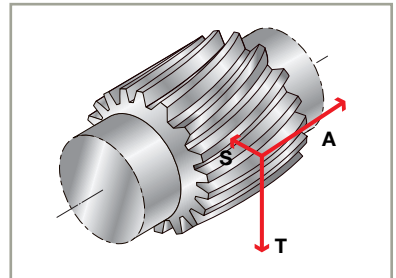

■ Straight-tooth bevel gear

$$T = T_p = T_c$$

α = pressure angle

$$S_p = -A_c = T \operatorname{tg} \alpha \cos \theta$$

θ = 1/2 angle at gear apex

$$A_p = -S_c = T \operatorname{tg} \alpha \sin \theta$$

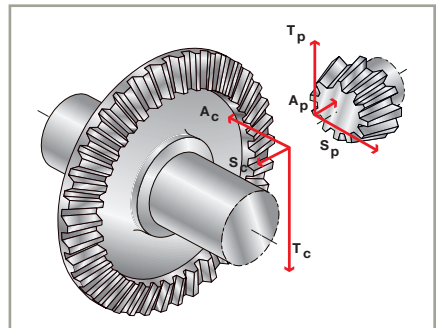

Appendices (continued)

■ Helical-tooth bevel gear

- D_p = pitch diameter of the driving gear
- D_c = pitch diameter of the driven gear
- L = tooth length
- D_p = mean diameter of the driving gear
- D_c = mean diameter of the driven gear
- T_p = tangential force of the driving gear
- T_c = tangential force of the driven gear

$$T_c = T_p = 2 C / D_p$$

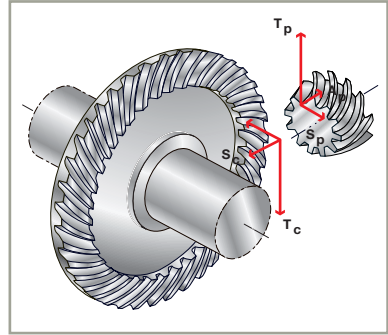

- α = pressure angle
- γ_p = helix angle of driving gear
- γ_c = helix angle of the driven gear
- ($\gamma_p = \gamma_c$ for straight-tooth and helical-tooth bevel gear pairs)

- β_p = 1/2 angle at apex of driving gear
- β_c = 1/2 angle at apex of driven gear

Direction of gear rotation:

(for an observer standing on the large base of the cone and looking at the apex)

- + counter-clockwise
- clockwise

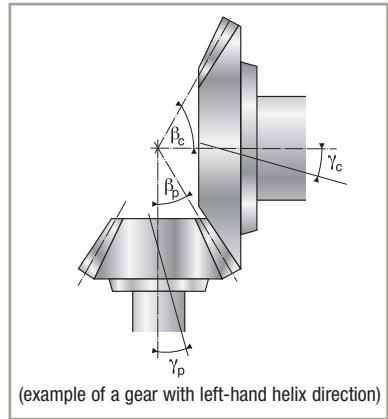

Direction of the helix	Direction of gear rotation	Separation force	Axial force
right or left	- +	Driving gear (moving away from driven gear) $S_p = \frac{T_p}{\cos \gamma_p} \cdot (\text{tg} \alpha \cos \beta_p + \sin \gamma_p \sin \beta_p)$ Driven gear (approaching driving gear) $S_c = \frac{T_c}{\cos \gamma_c} \cdot (\text{tg} \alpha \cos \beta_c - \sin \gamma_c \sin \beta_c)$	Driving gear (moving away from driven gear) $A_p = \frac{T_p}{\cos \gamma_p} \cdot (\text{tg} \alpha \sin \beta_p - \sin \gamma_p \cos \beta_p)$ Driven gear (approaching driving gear) $A_c = \frac{T_c}{\cos \gamma_c} \cdot (\text{tg} \alpha \sin \beta_c + \sin \gamma_c \cos \beta_c)$
right or left	+ -	Driving gear (moving away from driven gear) $S_p = \frac{T_p}{\cos \gamma_p} \cdot (\text{tg} \alpha \cos \beta_p - \sin \gamma_p \sin \beta_p)$ Driven gear (approaching driving gear) $S_c = \frac{T_c}{\cos \gamma_c} \cdot (\text{tg} \alpha \cos \beta_c + \sin \gamma_c \sin \beta_c)$	Driving gear (moving away from driven gear) $A_p = \frac{T_p}{\cos \gamma_p} \cdot (\text{tg} \alpha \sin \beta_p + \sin \gamma_p \cos \beta_p)$ Driven gear (approaching driving gear) $A_c = \frac{T_c}{\cos \gamma_c} \cdot (\text{tg} \alpha \sin \beta_c - \sin \gamma_c \cos \beta_c)$

Terminology

Vocabulary

Symbol	Description	Unit
α	nominal angle of contact	°
B	width of bearing inner ring	mm
C	width of bearing outer ring	mm
C	basic dynamic capacity of a bearing	N
C_0	basic static capacity of a bearing	N
C_e	equivalent basic dynamic capacity of an assembly	N
C_{0e}	equivalent basic static capacity of an assembly	N
D	outside diameter of the bearing	mm
D_w	mean diameter of the rolling element	mm
d	bearing bore diameter	mm
fc	factor for calculating the basic dynamic load	
f_s	safety factor	
F_a	total axial load on the bearing	N
F_r	total radial load on the bearing	N
J_a	theoretical axial clearance	mm
J_r	operating radial clearance	mm
i	number of rows of rolling elements	
l	effective length of the contact generating surface	mm
L_{10}	nominal service life	
N	speed of rotation	tr/mn
P	equivalent dynamic radial load of the bearing	N
P_0	equivalent static radial load of the bearing	N
T	nominal width of a tapered bearing	mm
X	radial factor of bearing	
X_0	static radial factor	
Y	axial factor of bearing	
Y_0	static axial factor	
Z	number of rolling elements	